

FAMO:

Mobiliário de escritório
Ping Pong

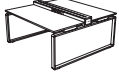

Working Together.

Ping Pong é uma linha de escritório que permite uma ocupação idónea do espaço: um sistema que se articula a partir de um módulo frente a frente (como sugere o nome), extensível a dois, três ou quatro módulos, integrando múltiplas soluções que permitem ordenar os acessórios. Uma composição evolutiva que favorece o intercâmbio e o trabalho de equipa e ao mesmo tempo respeita a intimidade de cada um. Design de Jean Louis Iratzoki.

Ping Pong es un programa de oficina que permite una ocupación idónea del espacio: un sistema que se articula a partir de un módulo frente a frente (lo que explica su nombre), extensible a dos, tres o cuatro módulos, integrando múltiples soluciones que permiten ordenar los accesorios. Composiciones evolutivas que favorecen el intercambio y el trabajo de equipo a la vez que se respeta la intimidad de cada uno. Diseño de Jean Louis Iratzoki.

Ping Pong est un programme de mobilier de bureau qui permet une occupation idéale de l'espace: un système qui s'articule d'un module face à face (d'ou son nom), extensible a deux, trois ou quatre, intégrant des solutions multiples qui permettent d'ordonner les accessoires. Compositions évolutives qui favorisent l'échange et le travail en équipe tout en respectant l'intimité de chacun. Design de Jean Louis Iratzoki.

Ping Pong is a office furniture program that allows an idoneous space occupation: a system that articulates from a module front to front (as its name suggests), extensible to two, three or four modules, integrating multiple solutions that allows the organization of accessories. One evolutive composition that favours the communication and team work and, at the same times, it respects the privacy of each one. Design of Jean Louis Iratzoki.

Haristeguy. Architects: Leibar&Seigneurin



01/ Ping Pong
P 06

Apresentação
Presentación
Présentation
Presentation

03/ Ping Pong
P 24

Modularidade
Modularidad
Modularité
Modularity

05/ Ping Pong
P 40

Decomposição
Despiece
Eclaté
Part breakdown

07/ Ping Pong
P 44

Designer
Diseñador
Designer
Designer

02/ Ping Pong
P 10

Instalação
Instalación
Installation
Instalation

04/ Ping Pong
P 38

Dimensões
Medidas
Dimensions
Measurements

06/ Ping Pong
P 41

Acabamentos
Acabados
Finitions
Finishes

08/ Ping Pong
P 44

Créditos
Créditos
Crédits
Credits



Ping Pong.



Working together

O Ping Pong. Exemplo de tática e estratégia. As situações aumentam à medida que o jogo avança, aumenta a velocidade, a segurança e a necessidade de prever os passos do outro jogador. Um jogo que requer uma total sincronização física e mental.

El Ping Pong. Ejemplo de tática y estrategia. Las situaciones inesperadas se incrementan a medida que el juego avanza, aumenta la velocidad, la seguridad, la necesidad de intuir los pasos del otro jugador. Un juego que requiere una total sincronización física y mental.

Le Ping Pong. Exemple de tactique et stratégie. Les stratégies inespérées augmentent au fur et à mesure que le jeu avance, augmente la vitesse, la sécurité, la nécessité de connaître les pas de l'autre joueur. Un jeu requière une totale synchronisation physique et mentale.

The Ping Pong. Example of tactics and strategy. Unexpected situations crop up more often as the game progresses, the speed increases, confidence grows, the need to sense the opponent's play is increasingly important. A game demanding total physical and mental synchronisation.

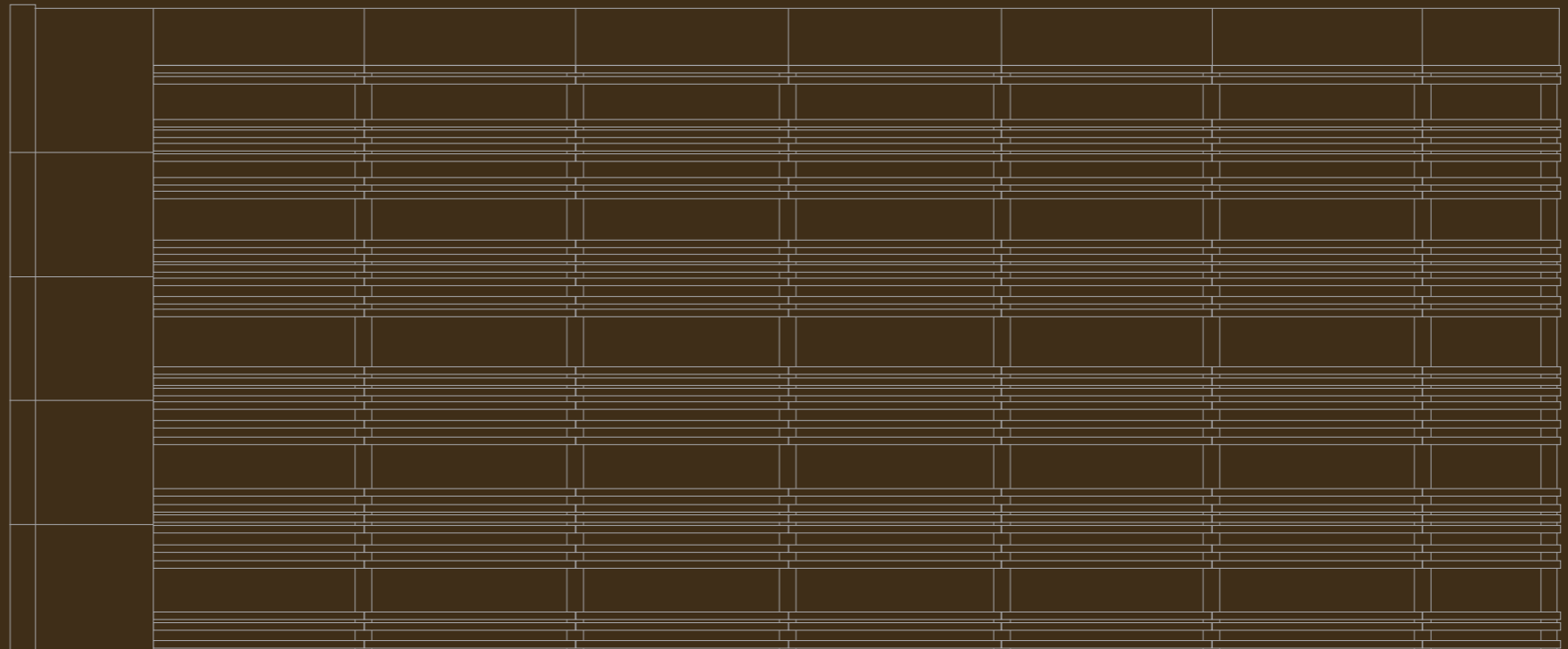

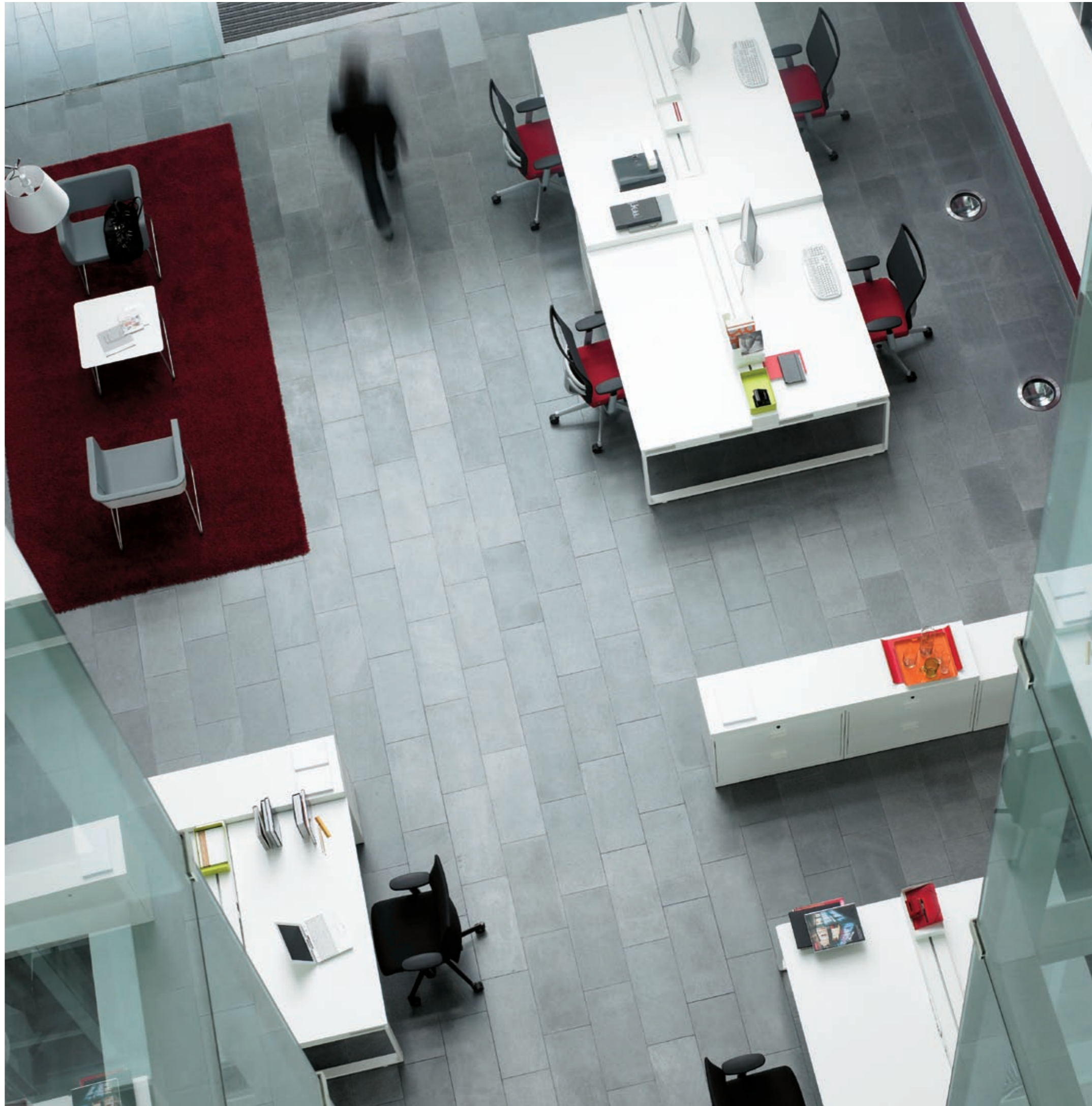











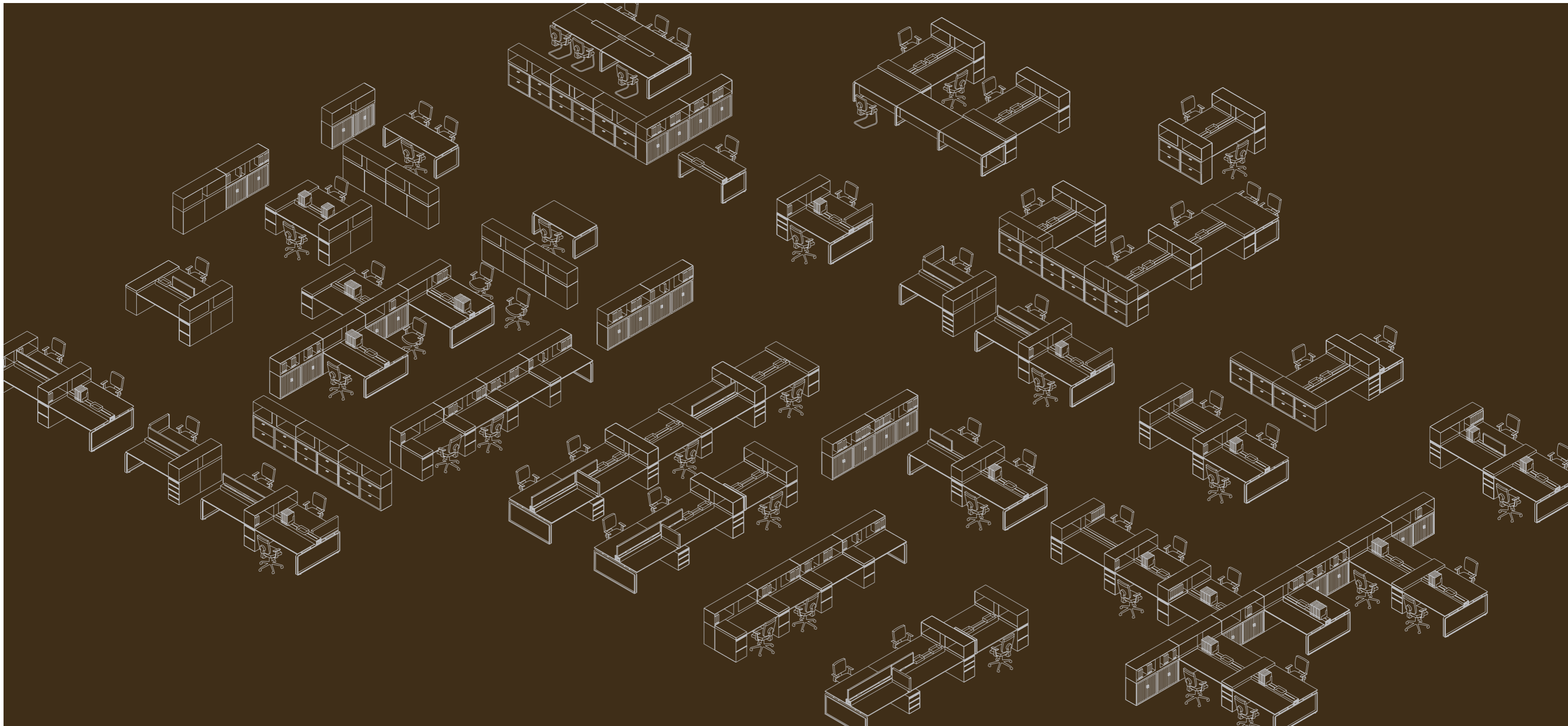



Postos duplos. Exemplo de construção com ou sem armazenagem / Puestos dobles. Ejemplo de construcción con y sin elementos de almacenaje / Postes doubles. Exemple de construction avec ou sans rangement / Double positions. Examples of construction with and without storage



Posto triplo com dois blocos e armário superior /
Puesto triple con dos bloques y armario superior /
Poste triple avec deux caissons et armoires
supérieures / Triple position with two pedestals and
upper cabinet





Postos quádruplos com elementos de armazenagem em posição central e inicial-final / Puestos quádruplos con elementos de almacenaje en posición central e inicial-final / Postes quádruplos avec éléments de rangement en position centrale e initiale-finale / Quadruple positions with storing in the middle and beginning-end



Os armários e mesas de reuniões são parte integrante do programa / Los armarios y mesas de reuniones son parte integrante del programa / Les armoires et tables de réunions sont partie intégrante du programme / The cabinets and conference tables are an integral part of the collection





Screen lateral
Separador lateral
Panneau latéral
Side separator

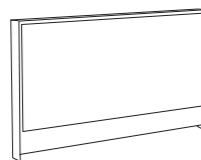

Acessório porta dossier
Accesorio porta-carpetas
Accessoires portes-dossiers
File holder accessory

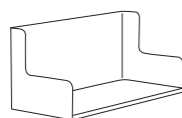

Screen frontal duplo
Separador lateral doble
Panneau latéral double
Double side separator

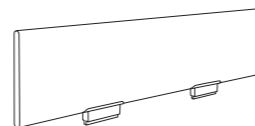

Screen frontal individual
Separador frontal individual
Panneau frontal individuel
Individual front separator

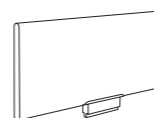

Acessório caixa porta-utilitários
Accesorio porta-utilitarios
Accessoires porte-ustensiles
Item holder accessory



Ping-Pong conta com varias soluções para dividir e ordenar, em distintos acabamentos e materiais / Ping Pong cuenta con variadas soluciones para dividir y ordenar, en distintos acabados y materiales / Ping-Pong comprend diverses solutions pour diviser et ordonner, avec différentes finitions et matériaux / Ping-Pong has several solutions to divide and order, with several finishes and materials

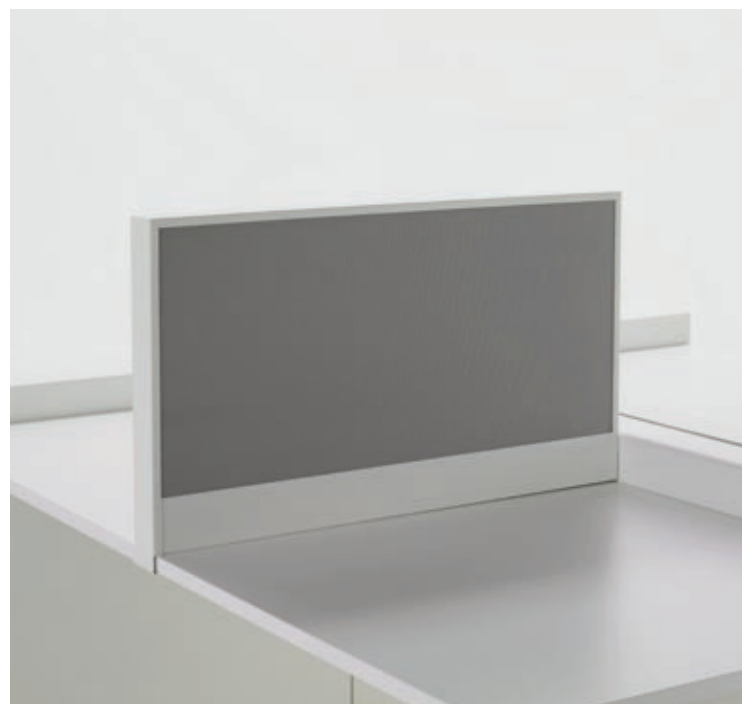

04/ Ping Pong.

Dimensões / Medidas / Measurements / Dimensions

SECRETÁRIAS / MESAS / TABLES / DESKS

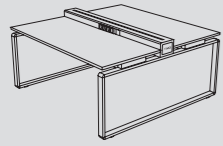

1200 X 1600
1400 X 1600
1600 X 1600
1800 X 1600
2000 X 1600
h: 720

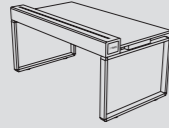

1200 X 890
1400 X 890
1600 X 890
1800 X 890
2000 X 890
h: 720

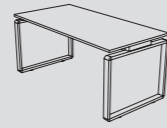

1200 X 800
1400 X 800
1600 X 800
1800 X 800
2000 X 800
h: 720

TAMPOS ESTRUTURAIS / TABLEROS ESTRUCTURALES / PLATEAUX STRUCTURAUX / STRUCTURAL TOPS

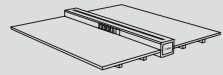

1200 X 1600
1400 X 1600
1600 X 1600
1800 X 1600
2000 X 1600
h: 170

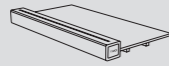

1200 X 890
1400 X 890
1600 X 890
1800 X 890
2000 X 890
h: 170

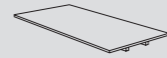

1200 X 800
1400 X 800
1600 X 800
1800 X 800
2000 X 800
h: 170

COLUNAS LATERAIS / COLUMNAS LATERALES / COLONNES LATÉRALES / LATERAL COLUMNS

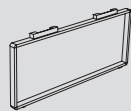

1600 X 60
h: 700



890 X 60
h: 700



800 X 60
h: 700

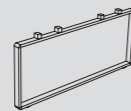

1600 X 60
h: 700



890 X 60
h: 700



800 X 60
h: 700

BLOCOS DE GAVETAS SUPORTE / CAJONERAS SOPORTE / CAISSONS SUPPORT / SUPPORT PEDESTALS

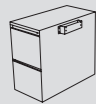

400 X 800
h: 720

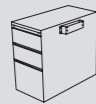

400 X 800
h: 720



400 X 800
h: 720



400 X 800
h: 620



400 X 800
h: 620

MESAS DE REUNIÃO / MESAS DE REUNIONES / TABLES RÉUNIONS / MEETINGS DESKS

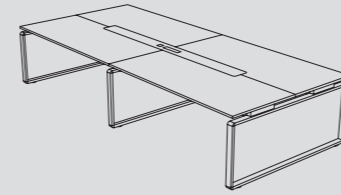

3600 X 1600
h: 720

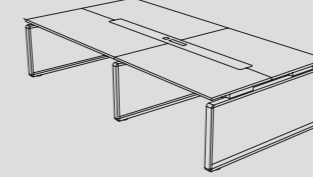

3000 X 1600
h: 720

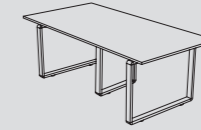

2400 X 1200
h: 720

ACCESSÓRIOS / ACCESORIOS / ACCESSOIRES / ACCESSORIES



1200 X 34
1400 X 34
1600 X 34
1800 X 34
2000 X 34
h: 380



800 X 34
h: 380



710 X 60
h: 250



300 X 220
500 X 220
h: 450



300 X 180
h: 100

TAMPOS PARA BLOCOS E ARMÁRIOS / ENCIMERA PARA BLOQUE Y ARMARIOS / TOP DE CAISSONS ET ARMOIRES / TOPS FOR PEDESTALS AND CUPBOARDS



1600 X 400
h: 70

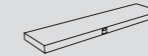

1600 X 400
h: 70



800 X 400
h: 70

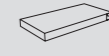

800 X 400
h: 70

ARMÁRIOS SUPERIORES / ARMARIOS SUPERIORES / ARMOIRES SUPÉRIEURES / TOP CUPBOARDS

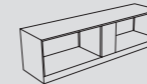

1600 X 400
h: 435

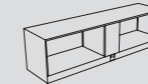

1600 X 400
h: 435

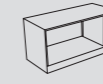

800 X 400
h: 435

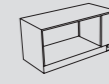

800 X 400
h: 435

BLOCOS DE GAVETAS RODADOS / CAJONERAS CON RUEDAS / CAISSONS À ROULETTES / MOBILE PEDESTALS



400 X 600
h: 575



400 X 600
h: 575



800 X 400
h: 720

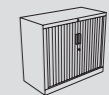

800 X 400
h: 720

ARMÁRIOS / ARMARIOS / ARMOIRES / CUPBOARDS

- ① Coluna lateral /
Columna lateral /
Colonne latérale /
Side column
- ② Tampa para coluna lateral / Tapa para columna lateral /
Enjoliveurs pour colonne latérale / Cover for side column
- ③ Travamento da secretária / Bastidor de la mesa /
Poutre du bureau /
Table frame
- ④ Bloco suporte lateral com 2 gavetas arquivo / Bloque soporte lateral con 2 cajones archivo / Caisson support avec 2 dossier suspendus / Support pedestal with 2 filing drawers
- ⑤ Bloco suporte lateral com 4 gavetas médias / Bloque soporte lateral con 4 cajones / Caisson support avec 4 tiroirs / Support pedestal with 4 drawers
- ⑥ Tampo / Encimera /
Plateau /
Worktop
- ⑦ Calha de electrificação / Viga de electrificación /
Poutre d'électrique /
Electrification beam
- ⑧ Tampo em chapa para bloco / Encimera metálica para bloque / Dessus métallique pour caisson /
Metal worktop for block
- ⑨ Armário superior para bloco / Armario superior para bloque / Armoire supérieur pour caisson /
Upper cabinet for block
- ⑩ Screen frontal duplo / Separador frontal doble /
Panneau frontal double /
Double front separator
- ⑪ Screen frontal individual / Separador frontal individual /
Panneau frontal individuel /
Individual front separator
- ⑫ Porta-dossiers / Porta-carpetas /
Porte-dossiers /
Item holder accessory
- ⑬ Screen lateral / Separador lateral /
Panneau latéral /
Side separator

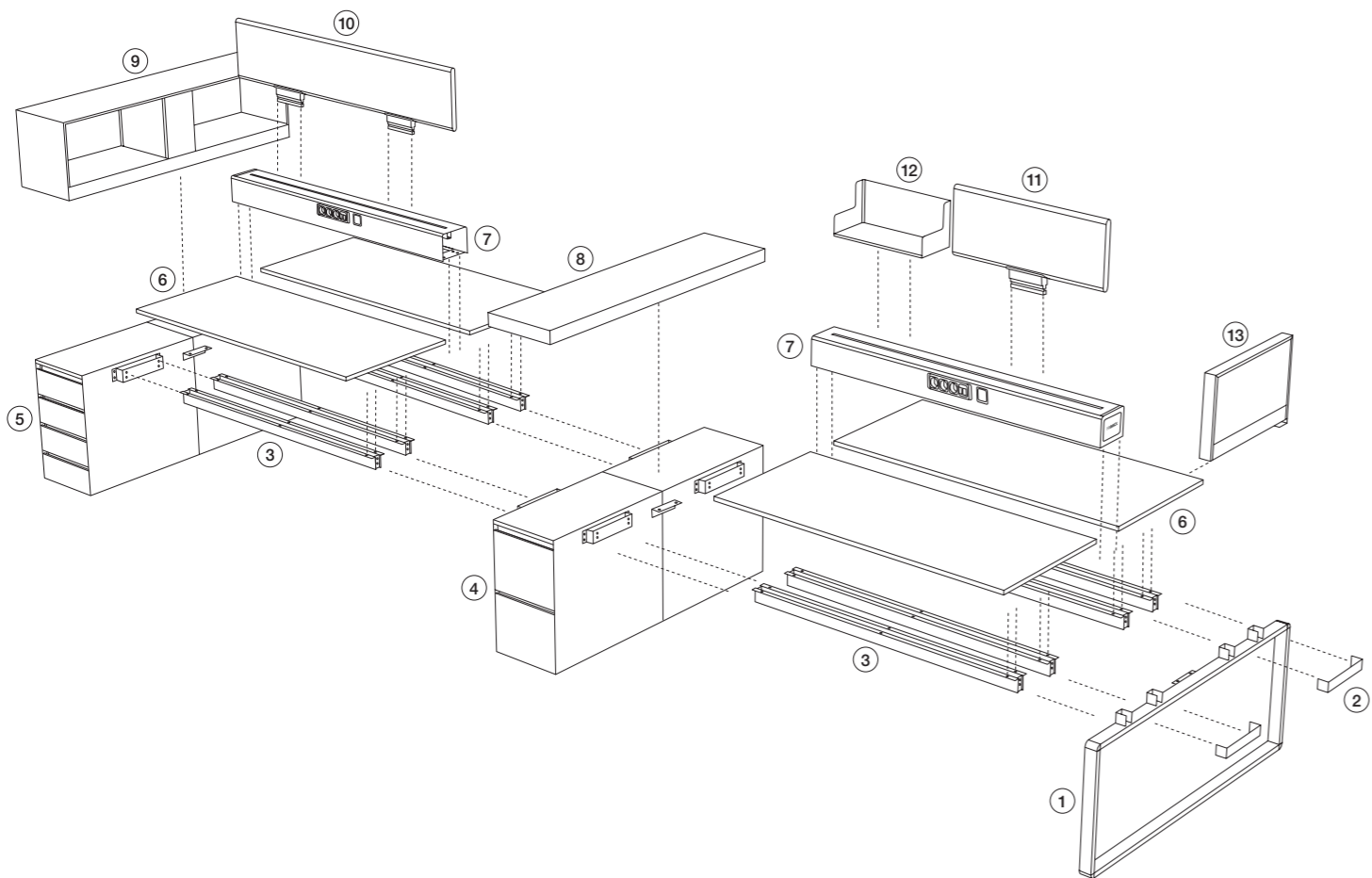

**TAMPOS / ENCIMERAS /
PLATEAUX / WORKTOPS**

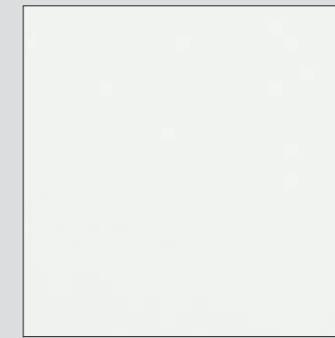

REF: 269. Branco / Blanco /
Blanc / White



REF: 276. Verde / Verde /
Vert / Green

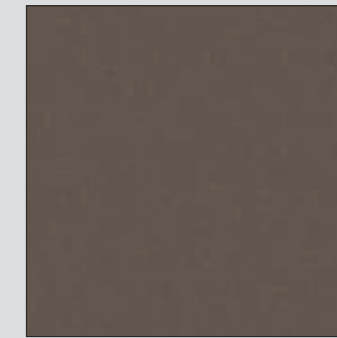

REF: 277. Cinzento / Gris /
Gris / Grey

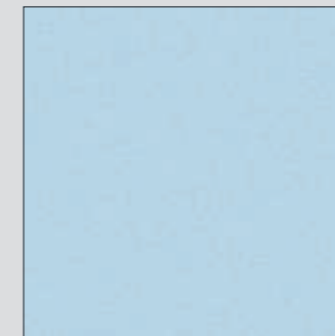

REF: 274. Azul / Azul /
Bleu / Blue



REF: 279. Maple / Maple /
Maple / Erable

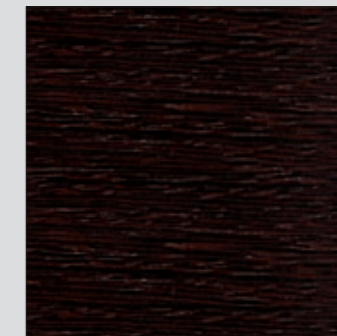

REF: 273. Wengué / Wengue /
Wenge / Wenge

**ESTRUTURA / ESTRUCTURA /
STRUCTURE / STRUCTURE**

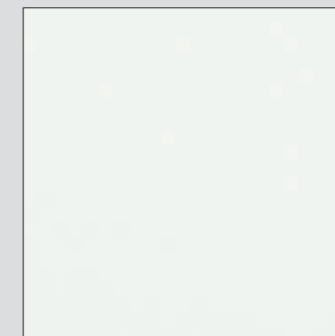

REF: 39. Branco / Blanco /
Blanc / White

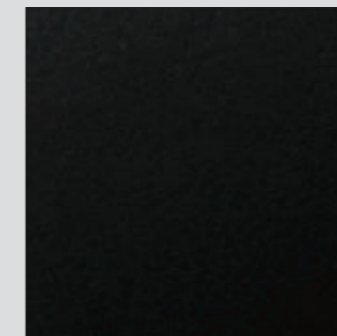

REF: 16. Preto / Negro /
Noir / Black

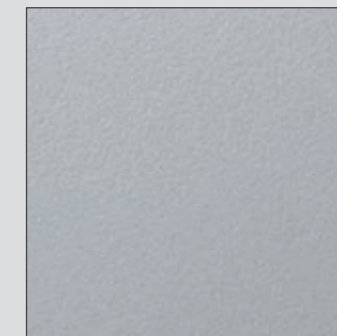

REF: 23. Alumínio / Aluminio /
Aluminium / Aluminium

FAMOX

Mobiliário de escritório
Ping Pong



07/ Ping Pong.

Designer / Diseñador / Designer / Designer

Jean Louis Iratzoki.

Designer industrial, nasceu em San Juan de Luz em 1965. Licenciado em arquitectura de design de interiores pela Escola Boule Paris, especializou-se em design industrial na Escola Superior Experimental de Madrid. Em 1998 abriu o seu próprio atelier de design no País Basco. Encontra-se actualmente activo no sector de desenho de mobiliário tanto para escritório como para casa, colaborando com conhecidas empresas internacionais.

Jean Louis Iratzoki.

Diseñador industrial nacido en San Juan de Luz en 1965. Diplomado en arquitectura de interior por la Escuela Boule-Paris, se especializa en diseño industrial en la Escuela Experimental de Madrid. En 1998 abre su propio taller de diseño en el País Vasco. Es el mundo del mueble al que se dedica últimamente, tanto mobiliario de oficina como de hogar, colaborando con conocidas empresas internacionales.

Jean Louis Iratzoki.

Designer industriel, né en 1965 à Saint-Jean-de-Luz. Diplômé en architecture intérieure à l'école Boule-Paris, il se spécialise en design industriel à l'École Expérimentale de Madrid. En 1998, il ouvre son propre atelier de design en Pays Basque. A l'heure actuelle il collabore avec de nombreuses entreprises internationales, créant du mobilier pour la maison comme pour le bureau.

Jean Louis Iratzoki.

Industrial designer, born in Saint Jean de Luz in 1965. Graduated in interior architecture at the Boule School-Paris and specialised in Industrial Design at the Experimental School of Madrid. In 1998 he opened his own design workshop. Recently he has been involved in the world of furniture, both office and home furniture, works together with international companies.



08/ Ping Pong.

Créditos / Créditos / Crédits / Credits

Fabricante do produto /
Fabricante de producto /
Product manufacturer /
Fabricant du produit :

FAMO

Realização do catálogo /
Realización de catálogo /
Réalisation du catalogue /
Catalogue by :

MARTIN & ZENTOL
www.myz.es

Impresión / Impressão /
Impression / Printing :

GRAFICAS UNDEFINED

Ano de edição / Año de edición /
Ane d'edition / Year of
publication :

3 / 2007

Agradecimentos /
Agradecimientos /
Agradeciments /
Thanks to:

Sr. Etchart
Edificio Haristeguy

FAMO

Indústria de Mobiliário de Escritório, Lda.
Rua 1º de Maio
4620-131 Lousada Portugal
T + 351 255 810 580 F + 351 255 810 589
lousada@famo.pt
www.famo.pt

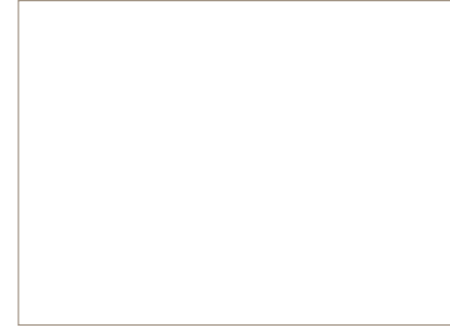

FAMO:

Working Together.

www.famo.pt